



# FLOOR MATTING AND MATS

## Heavy Corrugated Rubber

**FEATURES:** A solid, corrugated rubber matting construction designed for extra heavy duty service. Has a smooth-back finish

**FUNCTION:** To help protect floors in applications which warrant a thickness greater than 1/8".

**BENEFITS:** Easily beveled and perforated for entrance mats. Offers greater thickness providing extra long life, particularly where heavy wear and traffic conditions occur.

**APPLICATIONS:** Commonly used in heavy traffic areas. Also used on hard floors, aisles, and behind counters to reduce fatigue.

**Color:**

Black

**Sizes:**

- 3/16" x 36", 72"
- 1/4" x 24", 36", 48", 72"
- 3/8" x 72"

**Roll Length:**

- 3/16"-Approx. 25 yds.
- 1/4"-Approx. 25 yds.
- 72"-Approx. 12 yds.
- 3/8" x 72"-Approx. 6 yds.

**Weight:**

- 3/16"-Approx. 11 lbs./sq. yd.
- 1/4"-Approx. 15 lbs./sq. yd.
- 3/8"-Approx. 22 lbs./sq. yd.

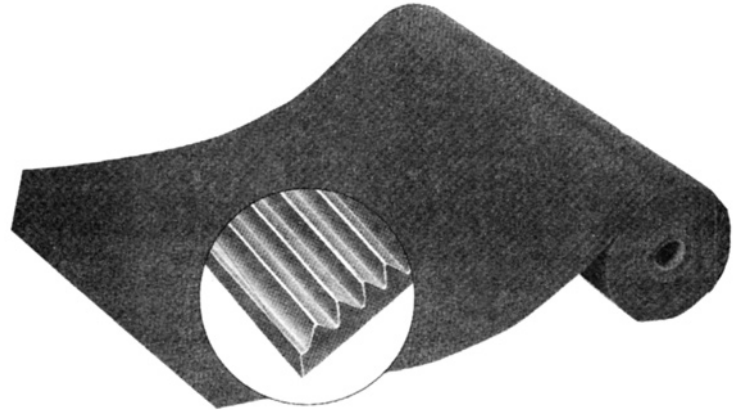
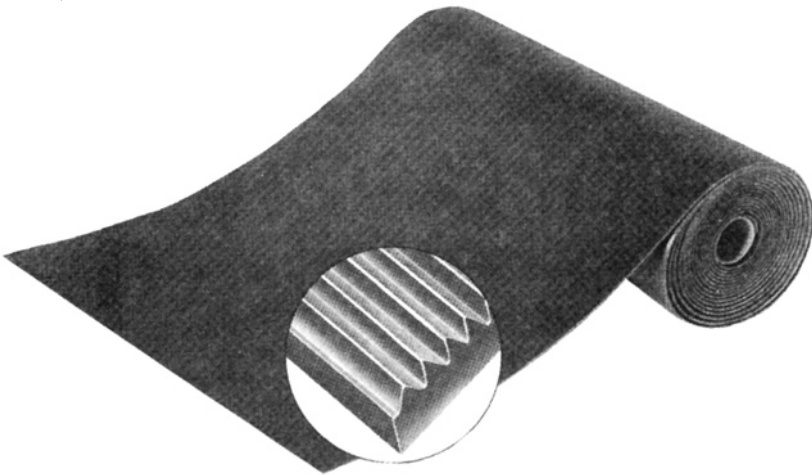

## 1/8" Standard Corrugated Rubber

**FEATURES:** A durable corrugated rubber runner engineered for a maximum service and long wear. Has a smooth-back finish. Available in half rolls approximately 25 yards and full rolls approximately 50 yards.

**FUNCTION:** Most widely used where floor protection and safety are vitally important.

**BENEFITS:** An all-weather product. Will not curl, shrink, or separate. Cleans easily and quickly, promotes cleanliness. Good abrasion resistance. Sound absorbing.

**APPLICATIONS:** Ideal for general use in industry, in the home, and office buildings.

**Colors:**

- Jet Black
- Russet Brown

**Sizes:**

- 1/8" x 24", 36", 48", 72"

**Roll Lengths:**

- Full Rolls-Approx. 50 yds.
- Half Rolls-Approx. 25 yds.

**Weight:**

- Approx. 6.3 lbs./sq. yd.

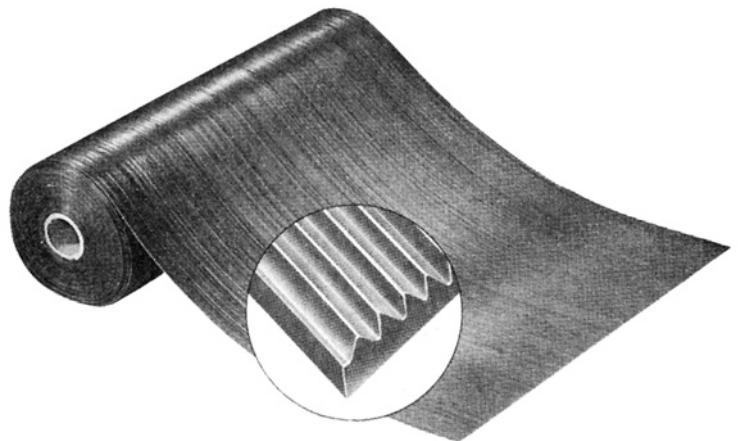

## Conductive Rubber Matting

**FEATURES:** Electronically conductive SBR rubber matting with corrugated face and plate black finish. Permanently branded on the back side with TCB CONDUCTIVE in 1" letters.

**APPLICATIONS:** Designed to carry off static electricity and prevent sparking in facilities that have highly dangerous areas such as arsenals, munitions plants and chemical plants.

**Surface:**

Corrugated

**Color:**

Black

**Roll Length:**

25 yds. ± 5 yds.

**Surface Resistivity:**

10<sup>4</sup> - 10<sup>6</sup> OHMS/Sq.

# FLOOR MATTING AND MATS



## A.S.T.M. SWITCHBOARD RUBBER MATTING

**FEATURES:** A corrugated all-rubber insulating matting specially compounded for use as a floor matting specially compounded for use as a floor covering for protection of workers.

**FUNCTION:** It is expressly designed to protect workers against electrical shock when working around high voltage apparatus within the product specifications.

**BENEFITS:** Conforms to ASTM D178-88 Type 1 Class 2. Proof tested at 20,000 volts AC. Maximum recommended use voltage is 17,000 volts. Dielectric strength 30,000 volts AC. Permanently branded on the back. Refer to specifications for additional information.

**Color:**

Black

**Size:**

1/4" x 24", 30", 36", and 48"

**Roll Length:**

Approx. 25 yds.

**Weight:**

Approx. 15 lbs./sq. yd.

Conforms to OSHA Regulations.

Ref. 29 CFR 1910.137 and 29 CFR 1910.309(b).

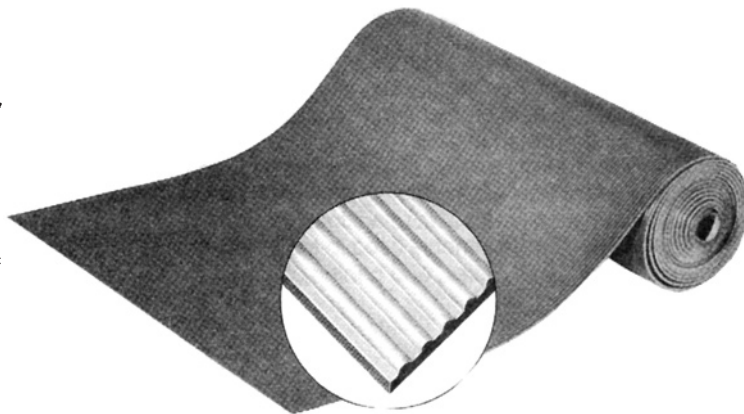

## GOLF SPIKE Easy-Sweep™ Design VINYL MATTING

**FEATURES:** A specially compounded vinyl runner available in three colors with a wide rib pattern.

**FUNCTION:** To protect floors against the damaging effects of golf spikes and ice skates.

**BENEFITS:** All-weather runner. Easy to clean. Sound absorbing. Long lasting.

**APPLICATIONS:** Pro shops, locker rooms, skating rinks, gymnasiums, stadiums, miniature golf courses, driving ranges, golf carts.

**Colors:**

Black  
Brown  
Green

**Size:**

1/4" x 36"

**Roll Length:**

25 yds.

**Weight:**

Approx. 16 lbs./sq. yd.

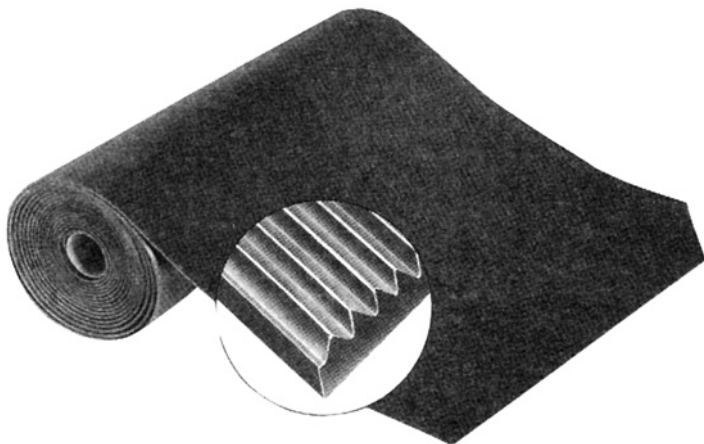

## GOLF SPIKE Kleen-rite™ Design RUBBER MATTING

**FEATURES:** A specially compounded rubber runner with a non-directional textured finish.

**FUNCTION:** To protect floors against the damaging effects of golf spikes and ice skates.

**BENEFITS:** All-weather runner. Easy to clean. Sound absorbing. Long lasting. Dimensionally stable.

**APPLICATIONS:** Pro shops, locker rooms, skating rinks, gymnasiums, stadiums, miniature golf courses, driving ranges, golf carts.

**Color:**

Black

**Size:**

3/16" x 36"

**Roll Length:**

Approx. 25 yds.

**Weight:**

Approx. 11.6 lbs./sq. yd.

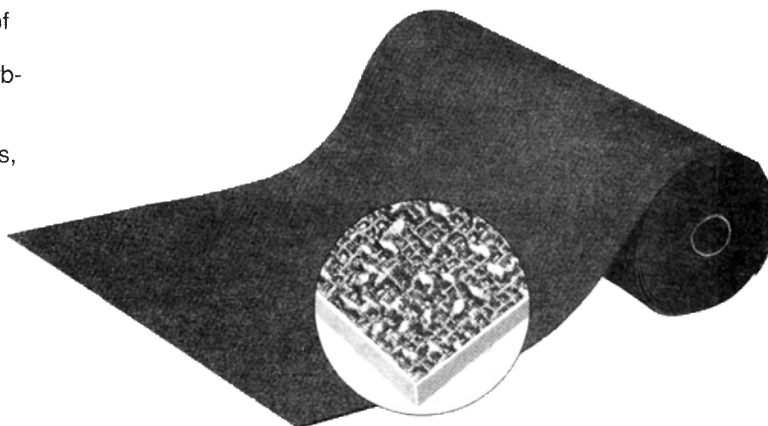



# FLOOR MATTING AND MATS

## Kleen-rite™ RUBBER MATTING

**FEATURES:** A lightweight, fine textured, all rubber runner with a non-directional design.

**FUNCTION:** Ideally suited for light duty applications, particularly on applications that have a smooth finish and require a textured surface.

**BENEFITS:** Cleans easily and quickly. Absorbs noise.

**APPLICATIONS:** Ideal for step stools, as a floor lining for car trunks, station wagons, trucks and farm equipment.

**Color:**

Black

**Sizes:**

Approx. .080" x 36", 48"

**Roll Lengths:**

Full Rolls-Approx. 50 yds.

Half Rolls-Approx. 25 yds.

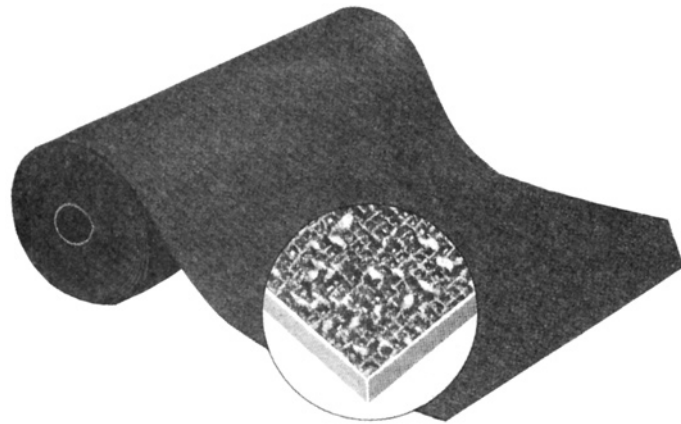
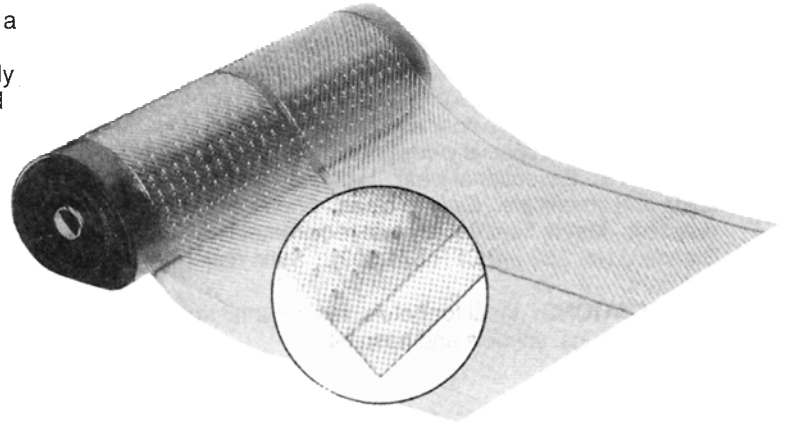

## Klear-Trac™ VINYL MATTING

**DESCRIPTION:** Klear-Trac™ runners are transparent, heavy duty, commercial gauge, industrial quality plastic matting products. They are designed to protect and enhance the decorative beauty and quality of fine carpets and other flooring products.

**BENEFITS:** Protects rugs and carpets against dirt, grime, grit, sand and moisture during periods of foul weather. Makes expensive carpets last longer. Saves maintenance time. Reduces replacement costs. Decreases excessive wear in high traffic areas.

**APPLICATIONS:** Homes, offices, entry ways, hallways, staircases... almost any indoor application.

**Color:**

Clear only

**Sizes:**

20 yd. rolls x 27", 36", 48" wide

**Weight:**

50 lbs., 86 lbs., and 112 lbs. (per carton)

**Material:**

Transparent, heavy duty, commercial gauge, non-marking plastic.

## ELDORADO VINYL MATTING

**FEATURES:** A lightweight, fine textured vinyl runner with a non-directional, attractive design. Textured back.

**FUNCTION:** Ideally suited for light duty applications, providing slip resistance for smooth surfaces.

**BENEFITS:** Cleans easily and quickly. Excellent abrasion resistance. Resists many acids and chemicals. Meets flammability test requirements for Motor Vehicle Standard No. 302 (49 CFR 571.302).Δ

**APPLICATIONS:** Light duty runner mat applications. The ideal product for die-cutting surfaces for step stools, fitness equipment, car trunks and other OEM applications.

**Color:**

Black

**Size:**

.075" x 36"

**Roll Length:**

35 yds.

**Weight:**

Approx. 4.7 lbs./sq. yd.

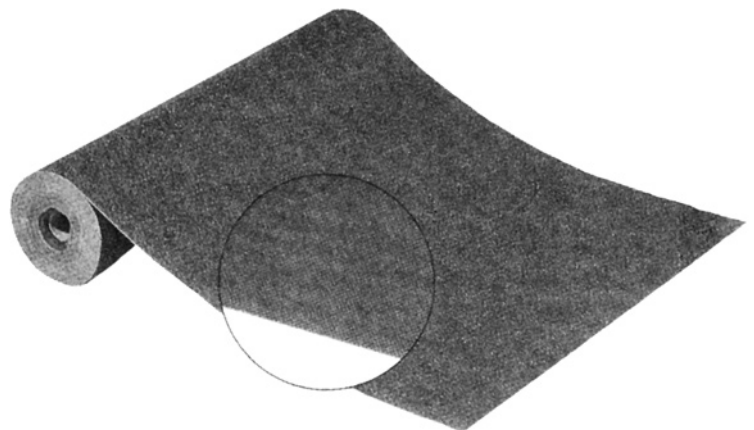

# FLOOR MATTING AND MATS



## Easy-Sweep™ VINYL MATTING

**FEATURES:** A durable vinyl runner with a round ribbed corrugation running lengthwise. Available in six appealing colors. Has a textured impression back.

**FUNCTION:** Protects floor and promotes safety. Our rib round corrugations are specially designed for ease of cleaning.

**BENEFITS:** Exceptional wear. Has good resistance to many acids and chemicals. Easy to clean. Improves traction. Tear resistant. Meets flammability test requirements of Motor Vehicle Standard No. 302 (49 CFR 571.302).<sup>Δ</sup> Stain resistant. Abrasion resistant.

**APPLICATIONS:** Ideal for hotels, restaurants, apartments, office buildings, schools and hospitals.

### Colors and Sizes:

Black - 1/8" x 24", 36", 48", 60"	Grey - 1/8" x 24", 36", 48"
Black - 1/4" x 36"	Green - 1/8" x 24", 36", 48"
Brown - 1/8" x 24", 36", 48", 60"	Terra Cotta - 1/8" x 24", 36"
Brown - 1/4" x 36"	White - 1/8" x 36" only

### Roll Length:

All 1/8" x 35 yds.  
All 1/4" x 25 yds.

### Weight:

1/8" - 6.8 lbs./sq. yd.  
1/4" - 16 lbs./sq. yd.

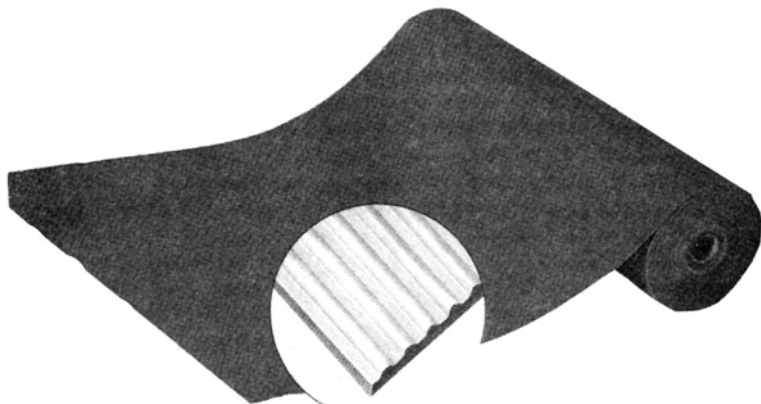

## CORRUGATED VINYL MATTING

**FEATURES:** A durable vinyl runner featuring angular pointed corrugations running lengthwise. Has a textured impression back.

**FUNCTION:** To provide floor protection and safety.

**BENEFITS:** Exceptional wear. Has good resistance to many acids and chemicals. Easy to clean. Improves traction. Tear resistant. Meets flammability test requirements of Motor Vehicle Standard No. 302 (49 CFR 571.302).<sup>Δ</sup> Stain resistant. Abrasion resistant.

### APPLICATIONS:

For general use in industry, restaurant, office buildings, schools and hospitals.

### Colors and Sizes:

Black - 1/8" x 24", 36", 48"	Blue - 1/8" x 36"
Black - 3/16" x 36"	Blue - 3/16" x 36"
Brown - 1/8" x 24", 36", 48"	

### Roll Length:

All 1/8" x 35 yds.  
All 3/16" x 25 yds.

### Weight:

1/8" - 6.8 lbs./sq. yd.  
3/16" - 11.5 lbs./sq. yd.

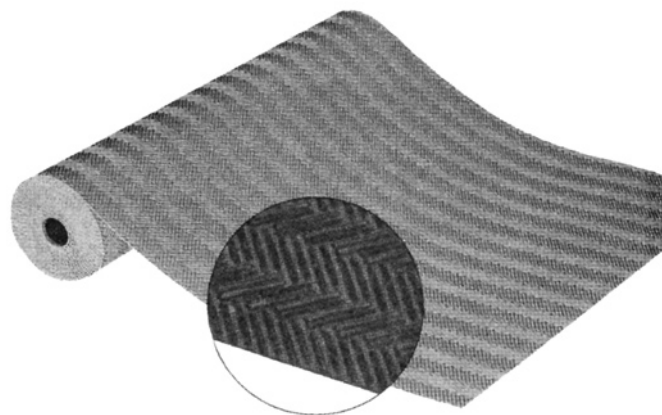
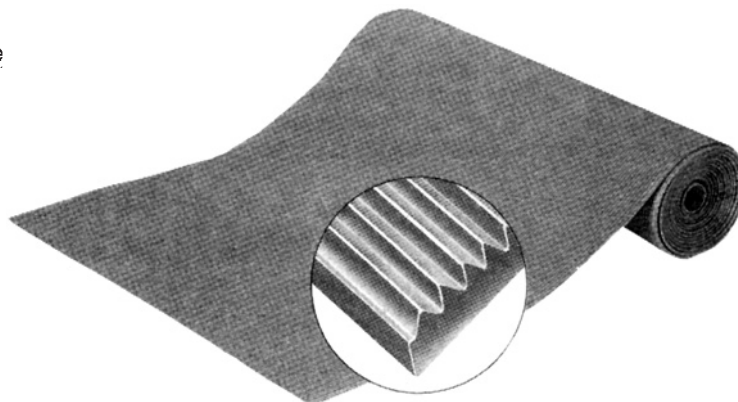

## Tuff-Trac™ VINYL MATTING

**FEATURES:** An attractive modern Herringbone ribbed interlocking surface design.

**FUNCTION:** Helps to provide added traction for employee and public protection from slippery or wet surfaces. The ribbed surface design removed particles and moisture from shoes and boots, trapping them on the runner.

**BENEFITS:** A special high grade vinyl compound that is durable and resistant to most oils. The ribbed design offers a slip-resistant pattern for greater safety and helps to reduce maintenance costs. Meets flammability test requirements of Motor Vehicle Standard No. 302 (49 CFR 571.302).<sup>Δ</sup>

### APPLICATIONS:

Ideal for hallways, entrance ways, corridors and aisles in airports, factories, office buildings, department stores, workstations and light manufacturing areas.

### Colors:

Jet Black	Bright White
Deep Brown	Charcoal Grey
Night Blue	Safety Yellow

### Sizes:

5/32" x 36"  
5/32" x 48"

### Roll Length:

25 yds.

### Weight:

7.5 lbs./sq. yd.



# FLOOR MATTING AND MATS

## NON-MILITARY DIAMOND VINYL MATTING

**FEATURES:** Biltrite Diamond Plate is a uniquely engineered, deeply-embossed, steel-deck design matting that offers an attractive, practical and commercial grade vinyl runner with a high technology appearance.

**FUNCTION:** Most widely used in heavy traffic areas where floor protection and safety are important.

**BENEFITS:** Exceptional wear characteristics make it ideal for heavy traffic. It has good resistance to most beverages, normal oils, usual household cleansers and common industrial chemicals. Meets flammability test requirements of Motor Vehicle Safety Standards No. 302 (49 CFR 571.302)<sup>A</sup>.

**APPLICATIONS:** Ideal for ramps and walkways, airports, restaurants, factories, office buildings and department stores.

**Colors:**  
Gray • Black • Brown

**Thickness:**  
5/32"

**Width:**  
36" and 48"

**Roll Length:**  
25 yds.

**Weight:**  
8 lbs./yd.



## PYRAMID VINYL MATTING

**FEATURES:** A uniquely engineered non-directional pattern combined with a special formulation resulting in an exceptionally slip-resistant vinyl runner.

**FUNCTION:** Primarily to be used where safety and floor protection are of major importance.

**BENEFITS:** Resists many oils and fats. Exceptional wear and long life. Reduces maintenance costs. Offers slip resistant pattern for greater safety. Meets flammability test requirements of Motor Vehicle Safety Standard No. 302 (49 CFR 571.302)<sup>A</sup>.

**APPLICATIONS:** Ideal for ramps, airports, walkways, factories, restaurants, office buildings, and department stores.

**Colors:**  
Black • Brown • White

**Sizes:**  
1/8" x 36" • 1/8" x 48" • White in 36" only

**Roll Length:** 35 yds.      **Weight:** 7 lbs./sq. yd.

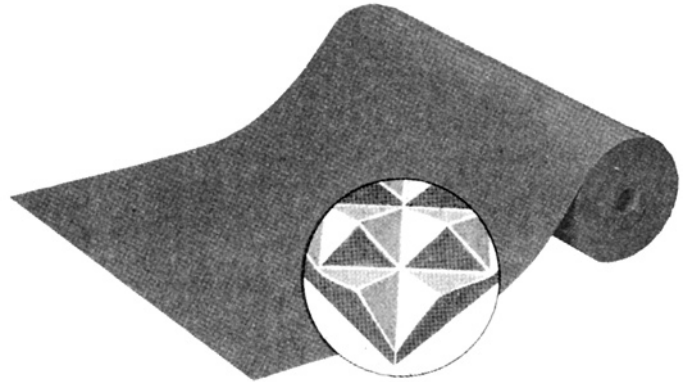

## Clean Trac™ RUBBER STUDED MATS

**FEATURES:**

- **Top surface**—The Hi studs clean shoes efficiently and help to prevent hydroplaning. The Lo studs trap dirt down deep in the mat and help reduce maintenance costs.
- **Underside**—Longitudinal ribs allow for proper drainage and at the same time act as a gripper which helps prevent the mat from moving.
- **Molded Edges**—Beveled edges on all four sides enhance safety and keep the dirt in the mat for easy disposal.

**BENEFITS:** Easy to clean—simply turn mat over and shake.  
**APPLICATIONS:** Clean Trac is an all-weather multi-purpose mat uniquely designed with thousands of Hi and Lo studs. Clean Trac serves as an excellent entrance mat and can be used at work stations for comfort and protection from hard and cold floors.

**Colors:**  
Black

**Approx. Size:**  
32" x 36"

**Weight:**  
13.5 lbs. per mat

**Material:**  
A high grade all-weather rubber compound

# FLOOR MATTING AND MATS



## 1/8" FEDERAL SPECIFICATION CORRUGATED VINYL

**FEATURES:** A vinyl runner featuring angular pointed corrugations. Textured back prevents slippage.  
**FUNCTION:** To provide floor protection and safety.  
**BENEFITS:** Specially formulated to meet Federal Spec. ZSM71F. Exceptional wear. Good resistance to many acids and chemicals. Easy to clean. Improves traction.

**Color:** Black  
**Size:** 1/8" x 36"  
**Roll Length:** 25 yards  
**Weight:** Approx. 7 lbs./sq. yd.

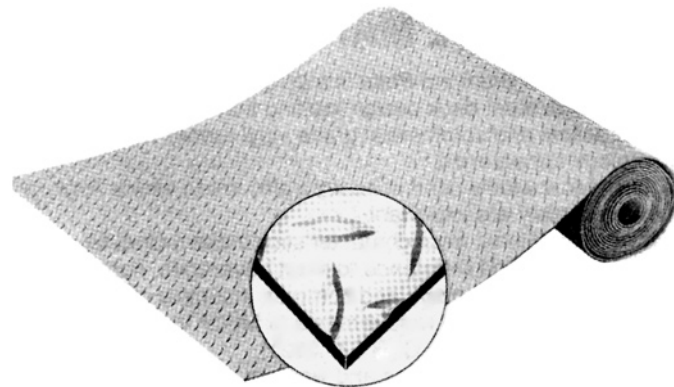
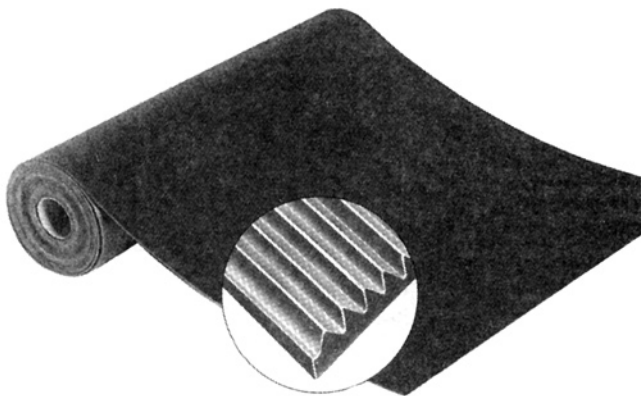

## MILITARY GRADE DIAMOND SWITCHBOARD VINYL MATTING

For use where neoprene military grade diamond switchboard is not specified. Conforms to MIL SPEC MIL-M-15562F Type III dated 12/7/77 as amended.

**APPLICATIONS:** Electrical apparatus, control panels and electrical circuitry.

**Colors:** Gray  
**Size:** 3/16" x 36"  
**Roll Length:** 25 yards  
**Weight:** Approx. 12.8 lbs./sq. yd.

## SMOOTH SWITCHBOARD VINYL MATTING

Conforms to MIL-M-15562F Type III dated 12/7/77 as amended. Oil, ozone, corona and fire resistant.

**APPLICATIONS:** Designed to protect workers against electrical shock when working around high voltage apparatus within the product specifications.

**Surface:** Smooth  
**Colors:** Black • Blue • Green  
**Size:** 1/8" x 36"  
**Roll Length:** 25 yards  
**Weight:** 9.1 lbs./sq. yd.

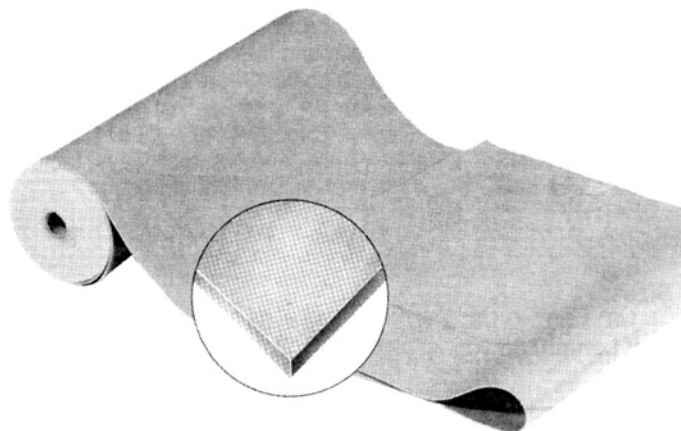



# FLOOR MATTING AND MATS

## Tredair™ INTERLOCKING COMFORT MATTING

**FEATURES:** Available in either standard or grease resistant. A cushioned mat approximately 1/2" thick. Underside constructed of numerous honeycombed, square, air cells giving resilience and foot comfort. Beveled edges. Sections can be interlocked to form any length. Easy to install.

**FUNCTION:** To help prevent body fatigue, increase productivity and cut down on accidents.

**BENEFITS:** Promotes sure-footed walking. Reduces foot, leg, and back fatigue and also reduces tool and glass breakage. Provides workers with a comfortable work atmosphere which will improve morale.

**APPLICATIONS:**

- *STANDARD RUBBER in Black*
  - Airports
  - Banks
  - Barber Shops
  - Beauty Parlors
  - Assembly Lines
  - Cafeterias
  - Cleaners
- *GREASE RESISTANT RUBBER in Black and Brown*
  - Department Stores
  - Hospitals
  - Hotels
  - Libraries
  - Laboratories
  - Machine Shops
  - Print Shops
- Motels
  - Post Offices
  - Schools
  - Supermarkets
  - Restaurants
  - Service Stations

**Color:** Black, Brown

**Size:** 28" x 36"

**Weight:** 9.5 lbs. per mat

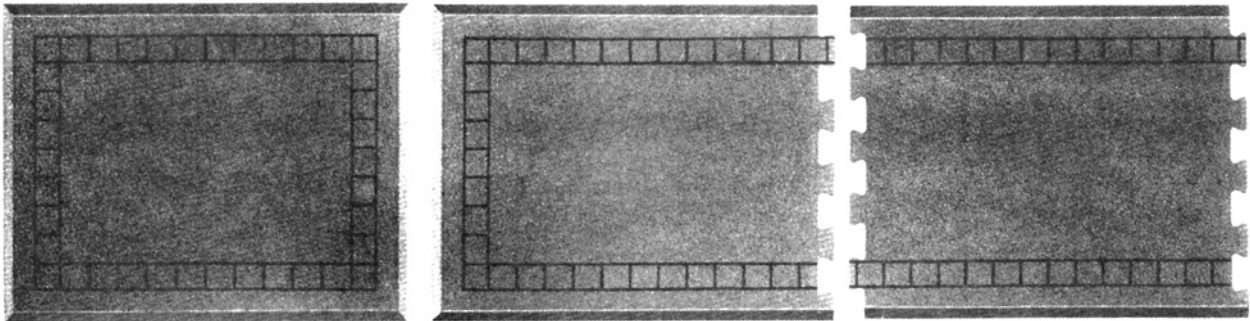

## Finger Trac™ RUBBER MATS

**FEATURES:**

- **Top Surface**—Designed with thousands of vertical rubber fingers to clean shoes of dirt, grit, sand, mud and snow. The fingers scrape shoe soles clean, eliminating ugly tracking problems and save on floor and rug maintenance.
- **Underside**—Longitudinal skid-resistant ribs allow for proper drainage and at the same time help prevent mat movement.
- **Molded Edges**—Beveled edges on all four sides enhance safety and prevent the dirt and other elements from running out over the floor.

**APPLICATIONS:** An all-weather multi-purpose mat. Available in three sizes to accommodate doorways from 32" to 72" widths. Can be used inside or outside, also ideal at work stations for comfort and protection from hard and cold floors.

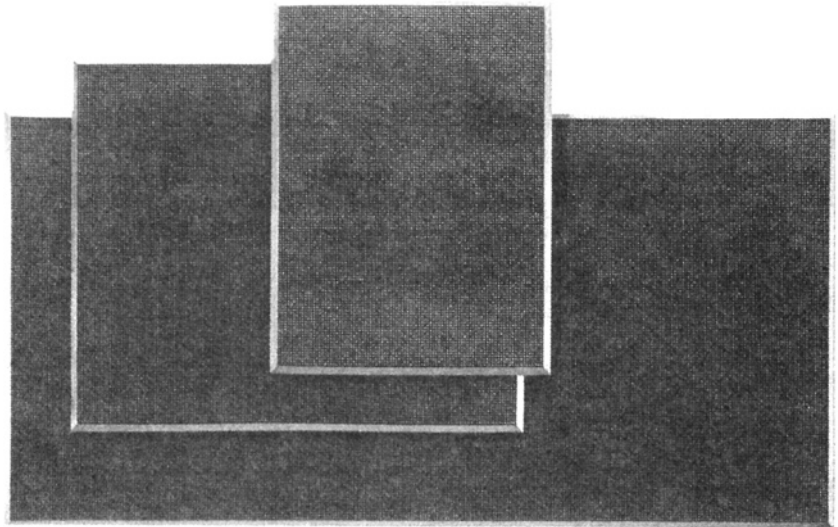

**Colors:**

Black

**Sizes:**

24" x 32" • 32" x 39" • 36" x 72"

**Weights:**

10 lbs. • 18 lbs. • 32 lbs.

**Material:**

A high grade all-weather rubber compound

# FLOOR MATTING AND MATS



## REFERENCE CHART

BILTRITE™ FLOOR MATTING PRODUCTS	Non-Directional Pattern	Textured Impression Back	Plate Back Finish	Military Grade	Black	Brown & Additional Colors	Electrical Protection	Resists Many Acids, Chemicals	*Flammability Test Requirements	Cleanability	Sound Absorbing	Round Ribbed	Will Not Stain Floors	Tear Resistant	Slip Resistant	Cleans Shoes	Anti-Fatigue
<b>RUBBER</b>																	
STANDARD 1/8" CORRUGATED			X		X	X				Good	X				Good	Excel.	Good
KLEEN-RITE™	X		X		X	X				Good	X				Good	Excel.	Good
MILITARY NEOPRENE DIAMOND SWITCHBOARD	X	X		X			X		X	Good	X			X	Good	Good	Good
GOLF SPIKE RESISTANT (Kleen-rite™)	X				X					Good	X			X	Good	Good	Good
HEAVY GAUGE CORRUGATED			X		X					Good	X			X	Good	Excel.	Good
A.S.T.M. SWITCHBOARD			X		X		X			Good	X			X	Good	Excel.	Good
CONDUCTIVE			X		X					Good	X			X	Good	Excel.	Good
<b>VINYL</b>																	
NON-MILITARY DIAMOND VINYL PLATE	X	X			X	X		X	X	Good	X		X	X	Good	Good	Good
MILITARY DIAMOND	X	X		X			X		X	Good	X			X	Good	Good	Good
MIL-SPEC SMOOTH	X	X		X			X		X	Good	X			X	Good	Good	Good
1/8" FED-SPEC CORRUGATED		X		X	X	X		X	X	Good	X		X	X	Good	Excel.	Good
ELDORADO		X			X	X		X	X	Good	X		X	X	Good	Excel.	Good
PYRAMID	X	X			X	X		X	X	Good	X		X	X	Good	Excel.	Good
CORRUGATED VINYL		X			X	X		X	X	Good	X		X	X	Good	Excel.	Good
EASY-SWEEP™		X			X	X		X	X	Excel.	X	X	X	X	Good	Excel.	Good
GOLF-SPIKE RESISTANT (Easy-Sweep)		X			X	X		X	X	Excel.	X	X	X	X	Good	Excel.	Good
KLEAR TRAC™								X		Good	X		X	X	Good	Excel.	
TUFF-TRAC™		X			X	X		X	X	Good	X		X	X	Good	Excel.	Good
<b>MATS</b>																	
TREDAIR INTERLOCKING (Anti-fatigue)					X	X				Good	X				Good	Good	Excel.
CLEAN-TRAC™					X					Good	X				Good	Excel.	Excel.
FINGER-TRAC™					X					Good	X				Good	Excel.	Good